



PURE TECHNOLOGY.

MECHANICAL FILTRATION SYSTEMS

For dust and smoke
**as single position,
mass or central extraction**

Md 90 | Md 200 | Md 300 | Md 400 | Md 600



LTA LUFTECHNIK. DEVELOPING THE FUTURE OF AIR FILTRATION.

With LTA Lufttechnik at your side, you can solve practically any filtration task. Our trained experts carry out research, development and production – with over 40 years of experience and in-depth understanding of customer requirements. This results in technological milestones for companies and groups around the world.

Why not turn our advanced knowledge into a lasting benefit for yourself? We will support you throughout the entire product life cycle, from advice and planning to installation and commissioning, through to professional services.

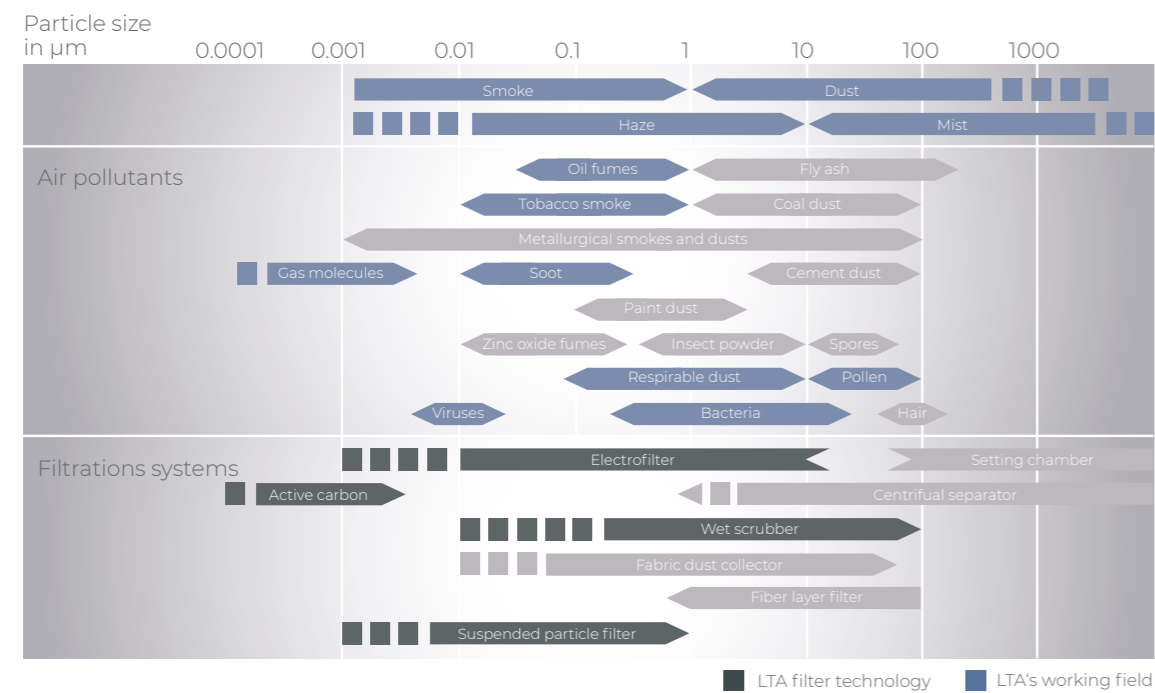

As a global full-range supplier, we produce solutions for compact filtration systems and plan and set up filtration systems for large extraction systems. We specialize in emulsion and oil mist, as well as dust and chip extraction, for particles ranging in size from 0.001 to 100 μm . Utilizing our expertise in the field of piping systems, flow simulations, safety technology and turn-key solutions, we create a whole range of added value for our customers across the entire life cycle of a system.

OUR FILTRATION SYSTEMS

ELECTROSTATIC FILTRATION SYSTEMS FOR COOLANTS As single position or mass extraction	MECHANICAL FILTRATION SYSTEMS FOR COOLANTS As single position or mass extraction	MECHANICAL FILTRATION SYSTEMS FOR DUST AND SMOKE As single position, mass or central extraction	AIR PURIFIER VIRUS CLEANER VC 60 Against viruses, bacteria, pollen and other germs
ELECTROSTATIC FILTRATION SYSTEMS FOR COOLANTS As mass or central extraction	MECHANICAL FILTRATION SYSTEMS FOR COOLANTS As mass or central extraction		

MECHANICAL FILTRATION SYSTEMS

For dust and smoke as single position, mass or central extraction



The mechanical particle filters for dust from LTA Lufttechnik are used to collect and remove dust and smoke of any kind. The filtration systems are used for simple industrial applications, but equally for complex industrial requirements and filtrations with special customer specifications. Cartridge and pocket filters are available for cleaning harmful particles.

The contaminated air is collected at the exhaust openings or with the help of an extraction arm, and led to the filtration system in a piping system. Then the contaminated air flows through the housing, where gravimetric removal of the larger particles occurs due to the decreasing air velocity. The air then flows through the filter chamber with filter pockets or filter cartridges, in which contaminations smaller than 1 µm and aerosols are removed. The air reaches the air outlet via the blower chamber. For the removal of ultra-fine dust or a huge variety of gaseous harmful substances or steam, a further filter chamber with suitably adapted filter elements can be installed upstream or downstream of the blower chamber. Finally, the clean air is led via the air outlet either into the collection area or outdoors via a piping system.



Our filter elements and their efficiency are **tested and confirmed according to DIN**. By the practiced quality system, **we continuously guarantee a high and consistent quality** of our systems. The **safety-related components** were also approved by the **IBExU** and have proven themselves on over 3000 machine tools worldwide.

EXTRACTION CAPACITY

from 900 to 6.000 m³/h (larger volume flow rates on request)

COLLECTION EFFICIENCY

up to 99,995 % (DIN EN 1822)

AREAS OF APPLICATION

- Removal of harmful dust particles in the course of the production process, e.g. in machine tools and machining centers as an individual or group suction system
- Collection and removal of soldering and welding fumes
- Extraction of harmful substances from 3D printers
- Special applications such as wet and dry processing, hardening systems or quenching baths

THE ADVANTAGES FOR YOU

- Protection of employees against particulate matter hazardous to health
- Low maintenance costs due to cleanable, reusable filter elements
- Efficient blower for optimal energy balance
- High availability and process reliability through variable use of different filter elements
- Filtration solutions from a single source: Consultation and project planning, flow simulation and heat recovery, commissioning and service
- Explosion and fire protection at machines with oil-cooled tools
- Compliance with all industrial and authority standards
- Certified according to ISO 9001 and ISO 14001

COMPACT



Md 90 - MPCIP

Extraction capacity: 900 m³/h
Dimensions (LxWxH): 650 x 550 x 1.205 mm
Weight: From 100kg
Operating voltage: 400 V



Md 200 - MPCIP

Extraction capacity: 2.000 m³/h
Dimensions (LxWxH): 850 x 750 x 2.460 mm
Weight: From 275 kg
Operating voltage: 400 V

STANDARD



Md 90 - CIP(X)

Extraction capacity: 900 m³/h
Dimensions (LxWxH): 750 x 650 x 2.270 mm
Weight: From 125 kg
Operating voltage: 400 V



Md 300 - CIP(X)

Extraction capacity: 3.000 m³/h
Dimensions (LxWxH): 1.050 x 850 x 2.920 mm
Weight: From 235 kg
Operating voltage: 400 V



Md 600 - CIP(X)

Extraction capacity: 6.000 m³/h
Dimensions (LxWxH): 1.050 x 1.500 x 2.920 mm
Weight: From 470 kg
Operating voltage: 400 V

HIGH-END



Md 200 - HCIP(X)

Extraction capacity: 2.000 m³/h
Dimensions (LxWxH): 980 x 930 x 2.970 mm
Weight: From 250 kg
Operating voltage: 400 V



Md 400 - HCIP(X)

Extraction capacity: 4.000 m³/h
Dimensions (LxWxH): 980 x 1.860 x 2.970 mm
Weight: From 500 kg
Operating voltage: 400 V



Md 600 - HCIP(X)

Extraction capacity: 6.000 m³/h
Dimensions (LxWxH): 980 x 2.790 x 2.970 mm
Weight: From 750 kg
Operating voltage: 400 V

DESIGN TYPES

COMPACT

- Pneumatic cleaning
- Collecting tanks in different variants
- Use in simple industrial applications and mobile systems

STANDARD

- With jet cleaning
- Collecting tanks in different variants
- Filter elements for multiple applications

HIGH-END

- With jet cleaning
- Collecting tanks in different variants
- Filter elements for multiple applications
- Customer-specific designs, e.g. country-specific regulations (e.g. CSA/UL 508 A), Customer-specific regulations (automotive), special voltage (110 V–480 V 50/60 Hz), etc.

VARIANTS

MPCIP

CLEANING WITH MECHANICAL-PNEUMATIC ACTUATION

Mechanical dust filters including built-in cleaning function with mechanical-pneumatic actuation.

CIP/HCIP

AUTOMATIC CLEANING SYSTEM

Automatic cleaning system with consistently high collection efficiency and permanent operational reliability. The filter elements are cleaned by a compressed air pulse.

CIPX/HCIPX

AUTOMATIC CLEANING SYSTEM WITH ADDITIONAL EXPLOSION PROTECTION

The filtration systems are equipped with additional explosion protection. For example, the filter chamber has protective measures regarding design. Furthermore, a three-phase blower in an explosion-proof design is used.

SELECTION CRITERIA

m³/h

WHAT EXTRACTION CAPACITY?

For dust filtration systems, a rate of 250 times per m³ and h is assumed as a guide value for air exchange. As an example, a machining area in the machine of 8 m³ and automated loading results in a required effective extraction capacity of approx. 2000 m³/h. In this example, therefore, a filtration system of the Md 200 series.

FUNCTIONALITY

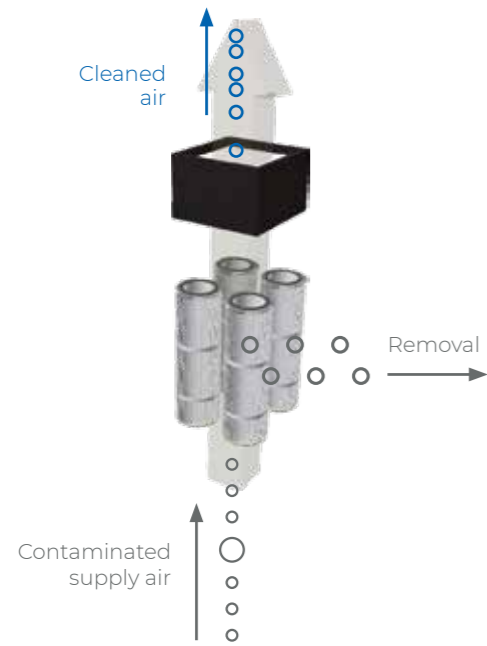

1 MAIN FILTER

The dust-laden air flows through the main filter. Cartridge filters are used to match the respective process requirement and ensure maximum possible particle removal. As a rule, this is already sufficient to comply with the legally required limit values in the cleaned air.

2 COLLECTING TANK

The dust removed by the filter cartridges falls into the collecting tank after cleaning.

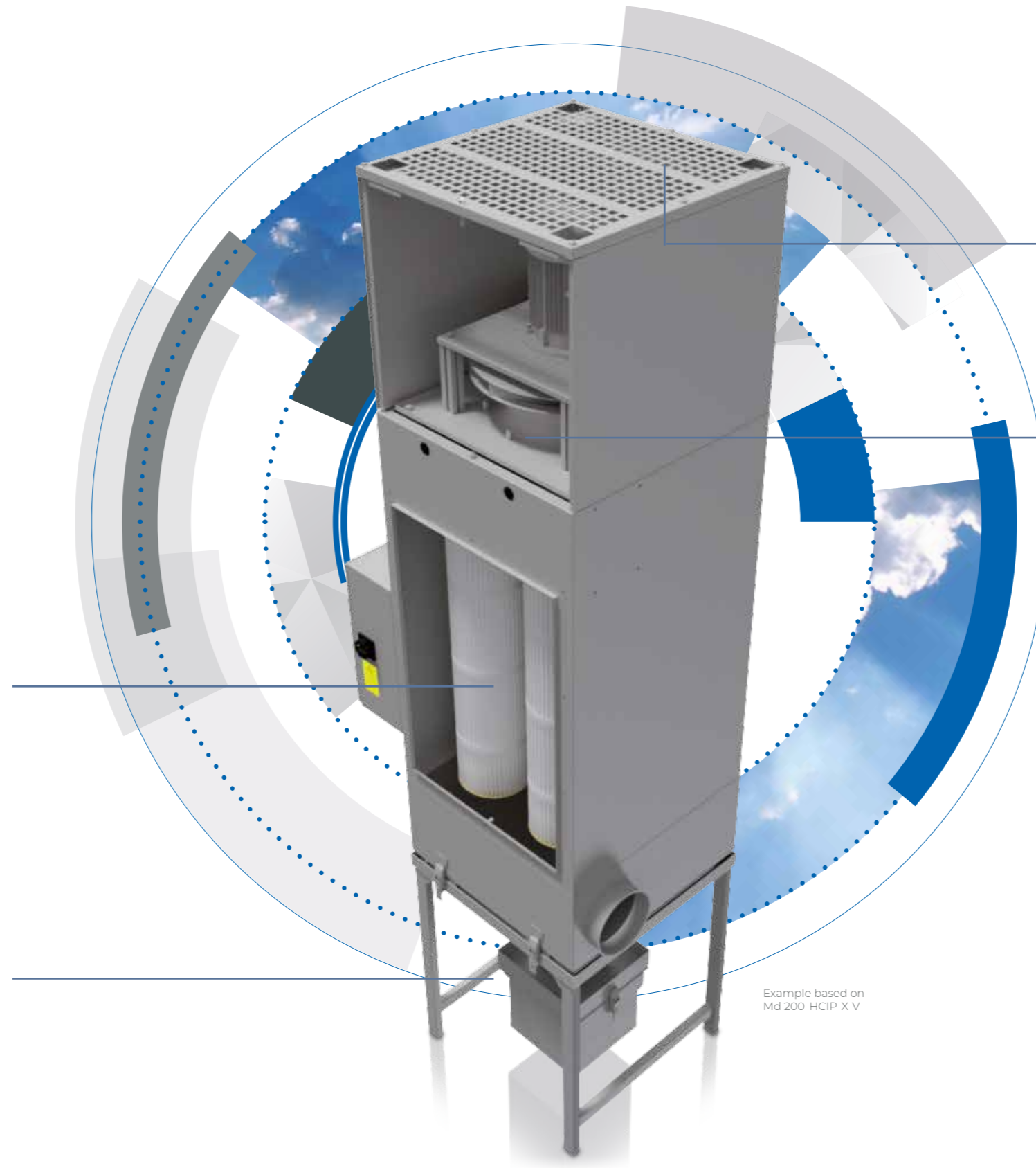

Example based on Md 200-HCIP-X-V

4

POST-FILTER (OPTIONAL)

The optional post-filters can, for example, be used against odors, smoke or substances hazardous to health as an additional level of security.

3

BLOWER

An energy-efficient blower sucks the air current over the connection opening through the air filter and conveys the cleaned air out of the housing.

COLOR SELECTION

The LTA standard paint is RAL 7035, light gray. Other colors/paints are always possible.

MAINTENANCE DOOR

The maintenance door at operating height allows easy access to the filter elements.

INTERFACES

LTA filtration systems are compatible with all standard machine control systems and regulations:

- Country-specific regulations (e.g. CSA/UL 508 A)
- Customer-specific regulations (automotive)
- Special voltage (110 V–480 V 50/60 Hz)

LTA LUFTECHNIK. YOUR PROFESSIONAL SUPPORT AROUND THE WORLD.

At LTA, we pride ourselves on working closely with our customers in the development of filtration solutions that precisely match actual customer requirements, and in the geographical sense. Our service network spans 7 countries worldwide, so our customers never need to wait longer than absolutely necessary for professional service.

Dedicated employees at all our sites provide professional support on all matters relating to industrial filtration. We ensure optimum availability of your filtration systems and see ourselves as the key to your productivity. Alongside our technical expertise, customers value our excellent availability and constructive collaboration.

24/7/365 LTA SERVICE

✉ service@lta-filter.com

☎ +49 7838 84-181



Even more flexible.
Even faster.

**OUR NEW
ONLINE SHOP**



WWW.LTA-FILTER.COM



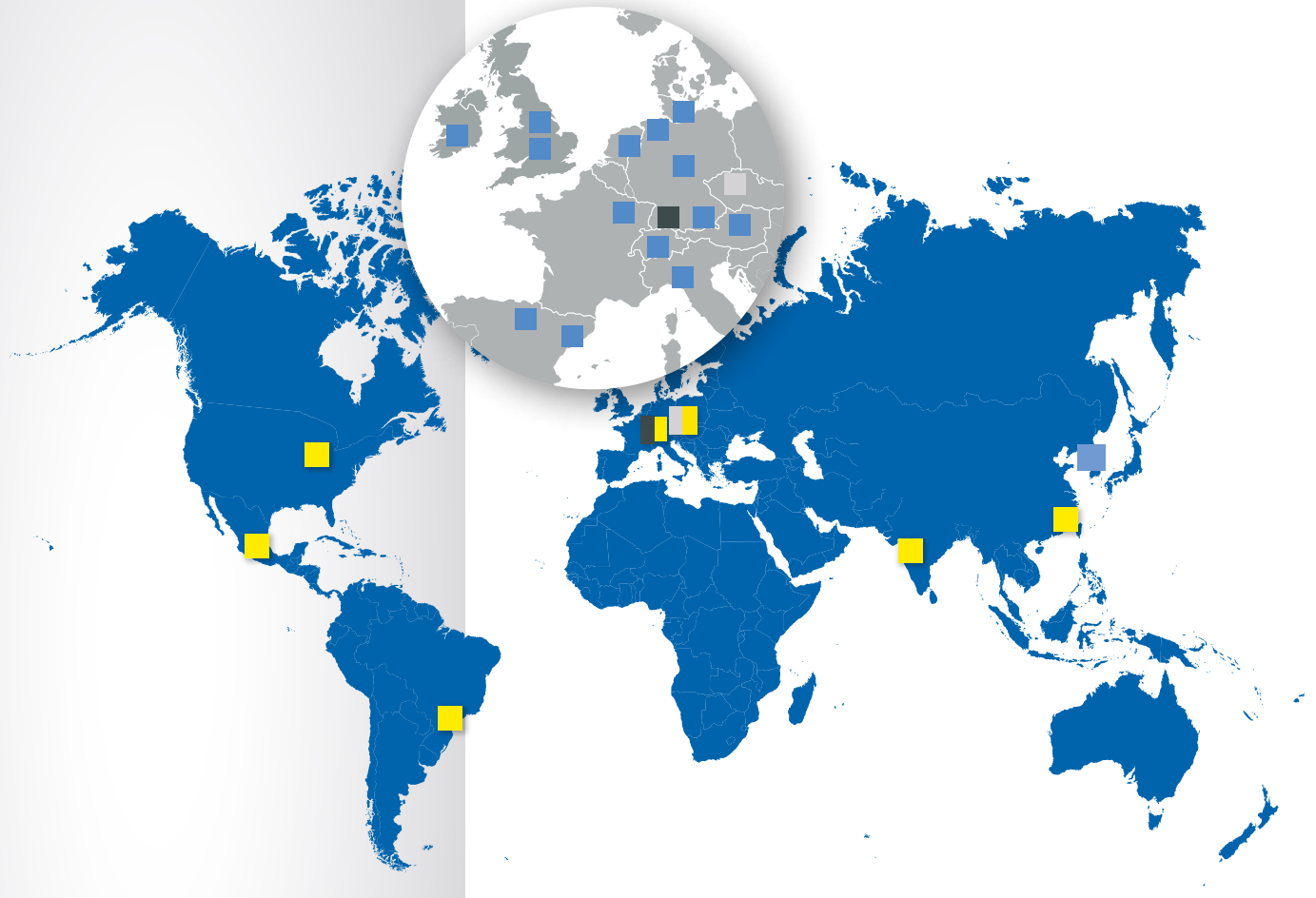

- Headquarters
- Production
- Agents and partners
- Sales and service locations

LTA Lufttechnik GmbH

Junkerstrasse 2
77787 Nordrach
Germany
info@lta-filter.com
+49 7838 84-245

**LTA Industrial Air
Cleaning Systems s.r.o.**

Lidická 66
252 68 Středokluky
Czech Republic
info@lta-filter.com
+420 233 012-113